

NOTES:

To extend 8ft. beyond pintle.

WIRING NOTES:

- A. WHITE: GROUND - 10
- B. BLACK: MARKER -12
- C. YELLOW: LEFT TURN & BRAKE - 12
- D. RED: STOP / BRAKE -12
- E. GREEN: RIGHT TURN & BRAKE - 12
- F. BROWN: TAIL - 12
- G. BLUE: ABS -12

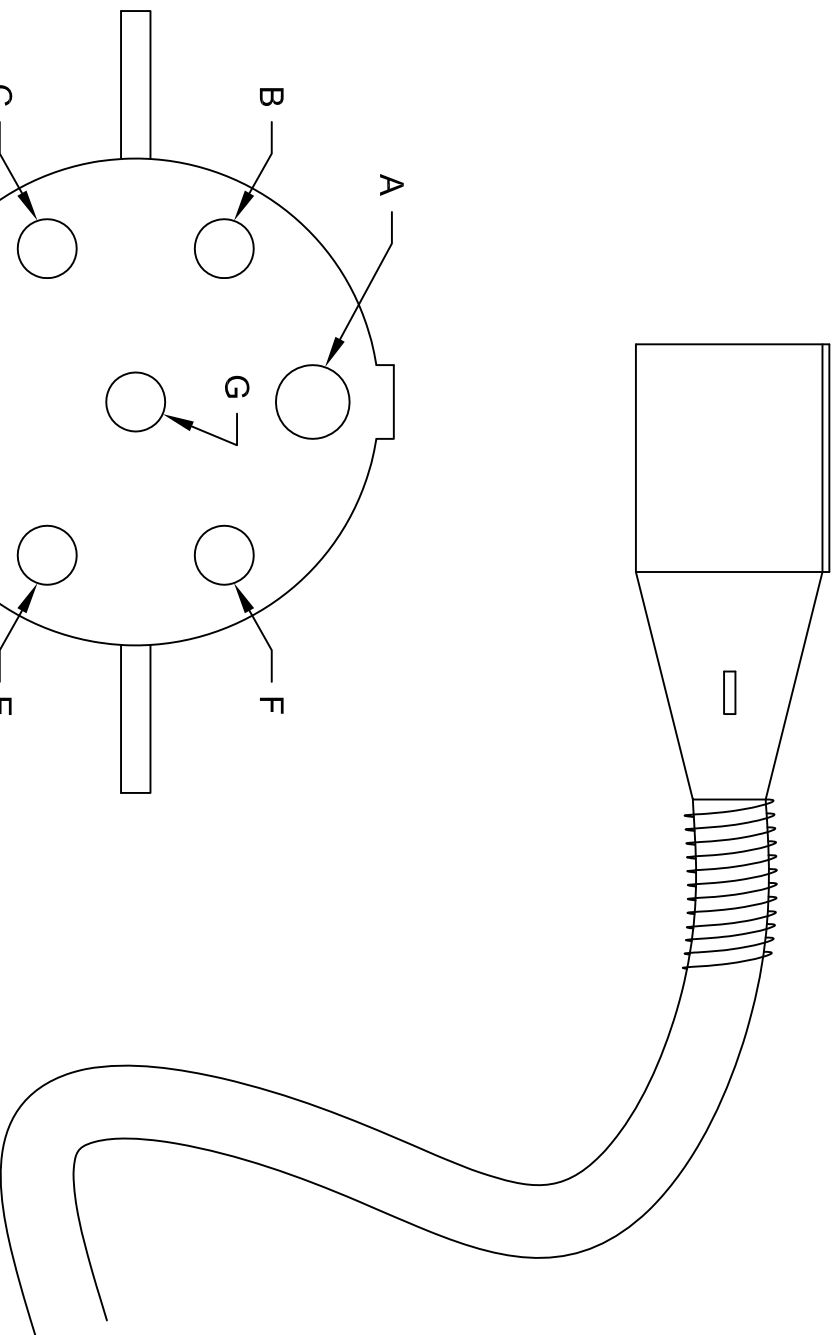

PA DEPARTMENT OF TRANSPORTATION

REVISIONS

NO.	DATE	BY	DESCRIPTION
1	5-16-2018	KBD	ROUND PIN MALE CONNECTOR
2			
3			

WIRING DIAGRAM / 7 WAY

ROUND PIN MALE CONNECTOR

DRAWN BY	SCALE	EQN-80B
JJB	N/A	
DATE	CHKD BY	SHEET 1 OF 1
08-02-16		

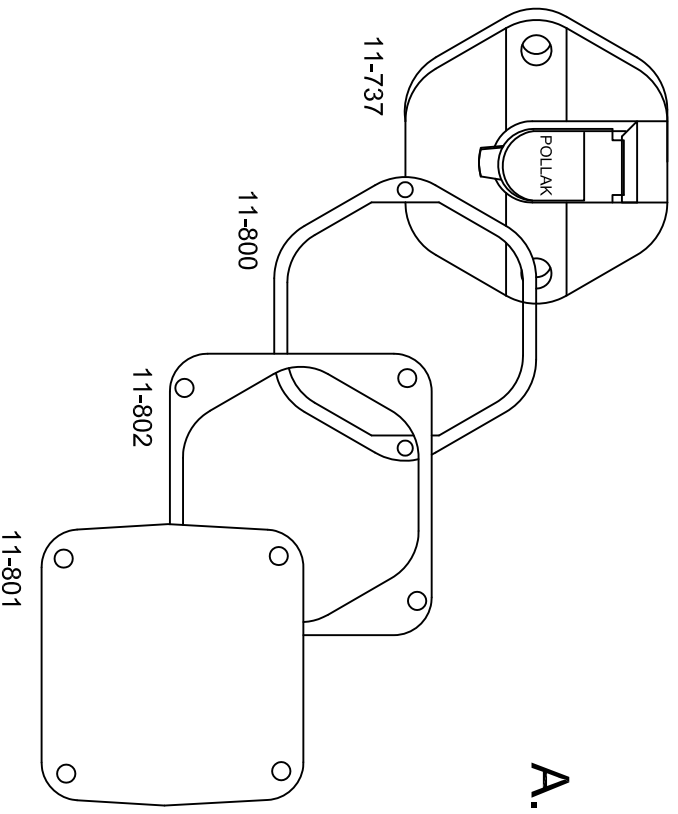

A. POLLAK / **B. TRUCKLITE**

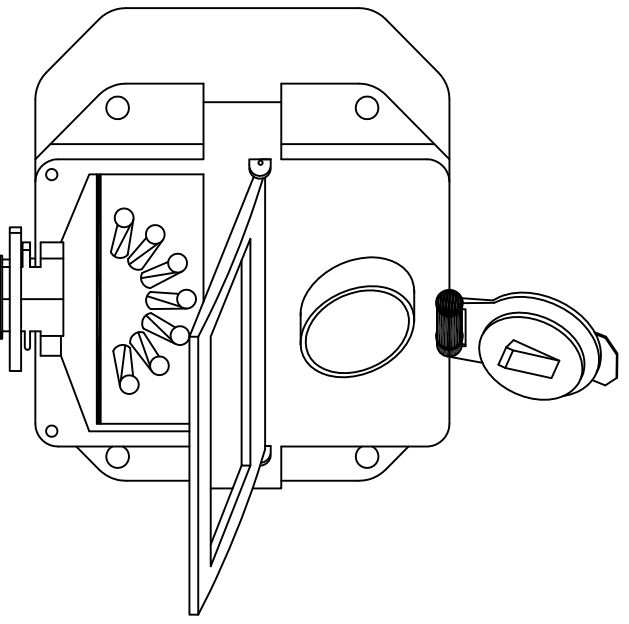

1. 7 WAY SPLIT PIN RECEPTACLE MEETING S.A.E. J5553 & J555A.
2. EXACT LOCATION SHALL BE DETERMINED UPON AWARD OF BID PRIOR TO PILOT MODEL.
3. WIRING SHALL BE IN CONFORMANCE WITH ATA COLOR CODING SYSTEM.
4. SEALED AND WEATHER-RESISTANT
5. REPLACEABLE CIRCUIT BREAKERS (15 AMP / OR 20 AMP).
6. REFERENCED ACCEPTABLE MODELS
 - A. POLLACK
 - 11-737
 - 11-800
 - 11-801
 - 11-802

(ALL ITEMS ARE REQUIRED TO MAKE UP THE COMPLETE ASSEMBLY)
 B. TRUCK-LITE PART NO. 50806-COMPLETE.

NOTE: NO SUBSTITUTE

REVISIONS				7 WAY TRAILER CONNECTOR			
NO.	DATE	BY		DATE	SCALE	CHECKED BY	SHEET
1	03-30-00	GAH		11-21-97	N/A	RED	1 OF 1
2	02-27-07	CJW					
3							

PA DEPARTMENT OF TRANSPORTATION

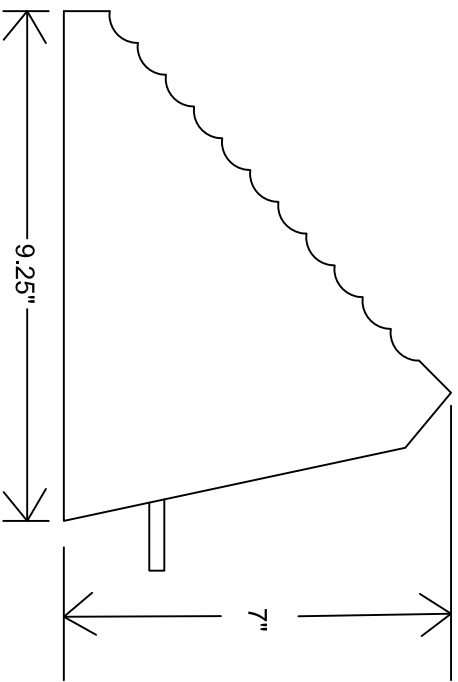

FINAL MOUNTING LOCATION SHALL BE DETERMINED AT THE PRE-BUILD MEETING. CHOCK HOLDERS SHALL BE ALUMINUM. TWO CHOCKS PER TRUCK SHALL BE SUPPLIED. CHOCKS SHALL HAVE 4 FEET OF $\frac{3}{8}$ INCH NYLON ROPE CONNECTING THE TWO CHOCKS TOGETHER.

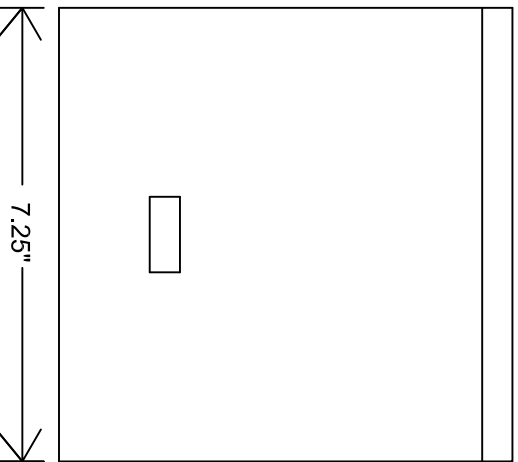
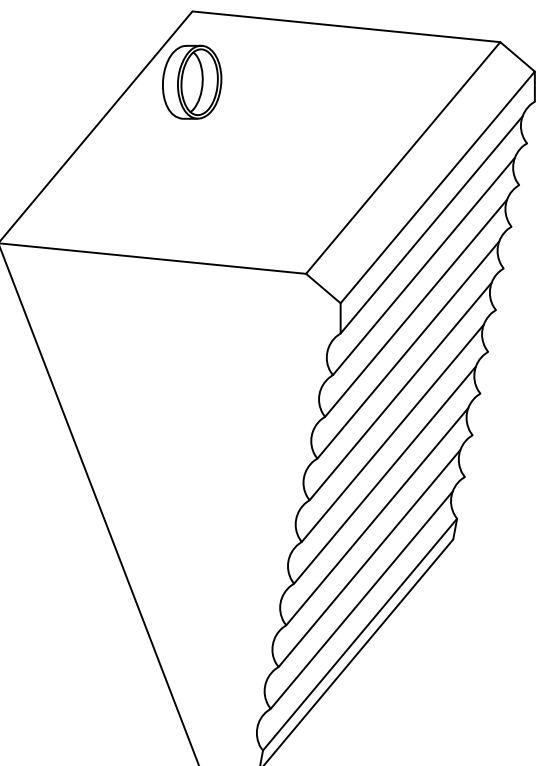

PA DEPARTMENT OF TRANSPORTATION

REVISIONS			7" X 9.25" X 7.25" CHOCK AND HOLDER		
NO.	DATE	BY	DATE	SCALE	
1					
2					
3					

NO.	DATE	BY	SCALE	
1				
2				
3				

NO.	DATE	BY	SCALE	
1				
2				
3				

SECTION 393.86 READS AS FOLLOWS: "EVERY MOTOR VEHICLE, EXCEPT TRUCK-TRACTORS, POLE TRAILERS, AND VEHICLES IN DRIVEWAY-TOWAWAY OPERATIONS, THE DATE OF MANUFACTURE OF WHICH IS SUBSEQUENT TO DECEMBER 31, 1952, WHICH IS SO CONSTRUCTED THAT THE BODY OR THE CHASSIS ASSEMBLY IF WITHOUT A BODY HAS A CLEARANCE AT THE REAR END OF MORE THAN 30 in. FROM THE GROUND WHEN EMPTY, SHALL BE PROVIDED WITH BUMPERS OR DEVICES SERVING SIMILAR PURPOSES WHICH SHALL BE SO CONSTRUCTED AND LOCATED THAT: (A) THE CLEARANCE BETWEEN THE EFFECTED BOTTOM OF THE BUMPERS OR DEVICES AND THE GROUND SHALL NOT EXCEED 30 in. WITH VEHICLE EMPTY; (B) THE MAXIMUM DISTANCE BETWEEN THE CLOSEST POINTS BETWEEN BUMPERS, OR DEVICES, IF MORE THAN ONE IS USED, SHALL NOT EXCEED 24 in.; (C) THE MAXIMUM TRANSVERSE DISTANCE FROM THE WIDEST PART OF THE MOTOR VEHICLE AT THE REAR TO THE BUMPER OR DEVICE SHALL NOT EXCEED 18 in.; (D) THE BUMPER OR DEVICES SHALL BE LOCATED NOT MORE THAN 24 in. FORWARD OF THE EXTREME REAR OF THE VEHICLE; (E) AND THE BUMPER OR DEVICES SHALL BE SUBSTANTIALLY CONSTRUCTED AND FIRMLY ATTACHED. MOTOR VEHICLES CONSTRUCTED AND MAINTAINED SO THAT THE BODY, CHASSIS, OR OTHER PARTS OF THE VEHICLE AFFORD THE REAR END PROTECTION CONTEMPLATED SHALL BE DEEMED TO BE IN COMPLIANCE WITH THIS SECTION."

THE REGULATIONS ALSO REQUIRE ALL MOTOR VEHICLES TRANSPORTING HAZARDOUS MATERIALS REQUIRING PLACARDING BE EQUIPPED WITH REAR END PROTECTION (REFERANCE 49CFR PART 397, 49 CFR SECTION 177.823, 49 CFR PART 172, AND 49 CFR SECTION 171.12A).

ALTHOUGH SECTION 393.86 DOES NOT SET FORTH SPECIFIC PERFORMANCE REQUIREMENTS FOR THE REAR END PROTECTION STRUCTURE, SUBPART J - SPECIFICATIONS FOR CONTAINERS FOR MOTOR VEHICLE TRANSPORTATION OF PART 178 - SHIPPING CONTAINER SPECIFICATIONS OF SUBCHAPTER C - HAZARDOUS MATERIAL REGULATIONS OF CHAPTER I - RESEARCH AND SPECIAL PROGRAMS ADMINISTRATION DOES CONTAIN SPECIFIC PERFORMANCE REQUIREMENTS FOR REAR END PROTECTION ON CARGO TANK MOTOR VEHICLES (REFERENCE SECTIONS 178.337-10(D), 178.338-10(C), 178.345-8(D), 178.346-8, 178.347-8, AND 178.348-8). PENNSYLVANIA HAS ADOPTED 49 CFR 393.86 REAR END PROTECTION FOR COMMERCIAL MOTOR VEHICLES WITH A GVW OF 17,000 lbs. / 7711.07 kg. OR MORE OPERATED IN INTRASTATE COMMERCE, AND ANY SIZE VEHICLE HAULING HAZARDOUS MATERIALS REQUIRING PLACARDS WITH AN ADDITIONAL REQUIREMENT: "SOME PART OF THE HORIZONTAL BUMPER BAR SHALL FALL WITHIN 16-30in. / 40.64-76.2cm. ABOVE GROUND LEVEL." SEE TITLE 67 CHAPTER 175 OF THE PENNSYLVANIA CODE FOR THE SPECIFIC REQUIREMENTS FOR REAR END PROTECTION ON COMMERCIAL MOTOR VEHICLES WITH A GVW OF 10,001-17,000 lbs. / 4536.38-7711.07 kg. OPERATED IN INTRASTATE COMMERCE.

**COMMONWEALTH OF PENNSYLVANIA
DEPARTMENT OF TRANSPORTATION**

REVISIONS

NO	DATE	BY	UNDERRIDE PROTECTION
1	07/08/97	DLW	
2	07/01/03	KGK	
3	06/26/09	TOD	

UNDERRIDE PROTECTION

	DRAWN BY	DLW	SCALE	N/A	EQN -118
	DATE	02-04-92	CHECKED BY	RR	SHEET 1 OF 1

**ANY / ALL REVISIONS SHALL
SUPERSEDE THE ABOVE**

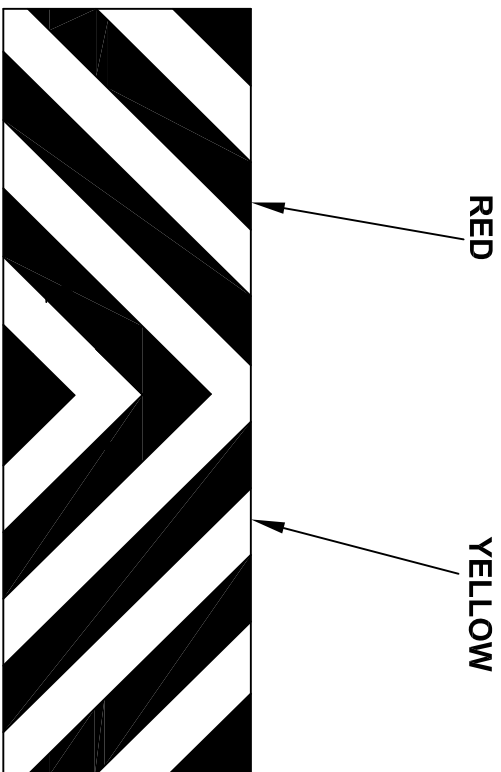

REAR BUMPER STRIPING

THE REAR BUMPER SHALL BE STRIPED AS SHOWN WITH 8" WIDE ALTERNATING RED/YELLOW BANDS CREATING A CHEVRON (INVERTED V) AT 45 DEGREE ANGLES, ACROSS THE BUMPER TO SERVE AS A SAFETY WARNING SYSTEM. TAPE SHALL BE REFLEXITE DAYBRIGHT V92 CONSPICUITY SHEETING. RED - SRH4R, YELLOW - SRH4Y. TWO 4" SHEETS CAN BE COMBINED TO EQUAL THE 8" REQUIREMENT.

THIS VEHICLE SHALL COMPLY WITH THE RULES OF THE NATIONAL HIGHWAY TRAFFIC SAFETY ADMINISTRATION (NHTSA). THE MOST CURRENT REGULATIONS SHALL BE ADHERED TO.

PA DEPARTMENT OF TRANSPORTATION

REVISIONS			REAR BUMPER REFLECTIVE SHEETING		
NO.	DATE	BY	DRAWN BY	SCALE	EQN-122 A
1			TOD	N/A	EQN-122 A
2			DATE 04-09-12	CHK'D BY TOD	SHEET 1
3					

THIS VEHICLE SHALL COMPLY WITH THE RULES OF THE NATIONAL HIGHWAY TRAFFIC SAFETY ADMINISTRATION (NHTSA) IN THAT:

THE MOUNTING HEIGHT OF THE HORIZONTAL STRIPES ARE RESTRICTED TO THE SAME HEIGHT AS OTHER RETROREFLECTIVE DEVICES CURRENTLY REQUIRED BY STANDARD NUMBER 108. THE CENTER OF THE MATERIAL MUST NOT BE LESS THAN 15in. ABOVE THE ROAD SURFACE, AND THE UPPER EDGE NOT MORE THAN 60in. ABOVE IT.

REFLECTIVE MATERIAL SHALL BE APPLIED TO THE HORIZONTAL BAR OF THE REAR UNDERIDE DEVICE IN ADDITION TO THE FLOOR LEVEL HORIZONTAL STRIPE. THE UPPER CORNERS ARE TO BE MARKED BY TWO 90 DEGREE ANGLE BRACKETS OF WHITE STRIPES 12in. BY TWO INCHES WIDE, INDICATING THE WIDTH AND HEIGHT OF THE TRAILER.

THE CONFIGURATION SHALL IDENTIFY THE VEHICLE AS TO ITS ESTIMATED SIZE AND THE CLOSING DISTANCE TO IT. THE DISTRIBUTION OF SPACES AND MATERIALS SHALL BE AS UNIFORM AS PRACTICAL AND INDICATE THE FULL LENGTH AND WIDTH OF THE VEHICLE. THE COLORS SHALL BE PLACED IN ALTERNATING SEQUENCE WITH MORE THAN TWO-THIRDS OF THE MATERIAL IN COLOR.

CONSPICUITY TAPE SHALL BE REFLECTORIZED. 2in. WIDE, MATERIAL SHALL BE APPLIED. MATERIAL SHALL BE RED/SILVER CONTINUOUS BACKING REFLEXITE CONSPICUITY II SYSTEM OR 3M SCOTCHLITE CONSPICUITY SHEETING SERIES 980.

THE MOST CURRENT REGULATIONS SHALL BE ADHERED TO.

REVISIONS			CONSPICUITY TAPE STRIPING REQUIREMENTS		
NO.	DATE	BY	DRAWN BY	SCALE	EQN-127A
1	05-16-02	DWG	DLW	N/A	EQN-127A
2	11-03-06	CJW	DLW	N/A	EQN-127A
3	01-02-09	MHH	DLW	N/A	EQN-127A

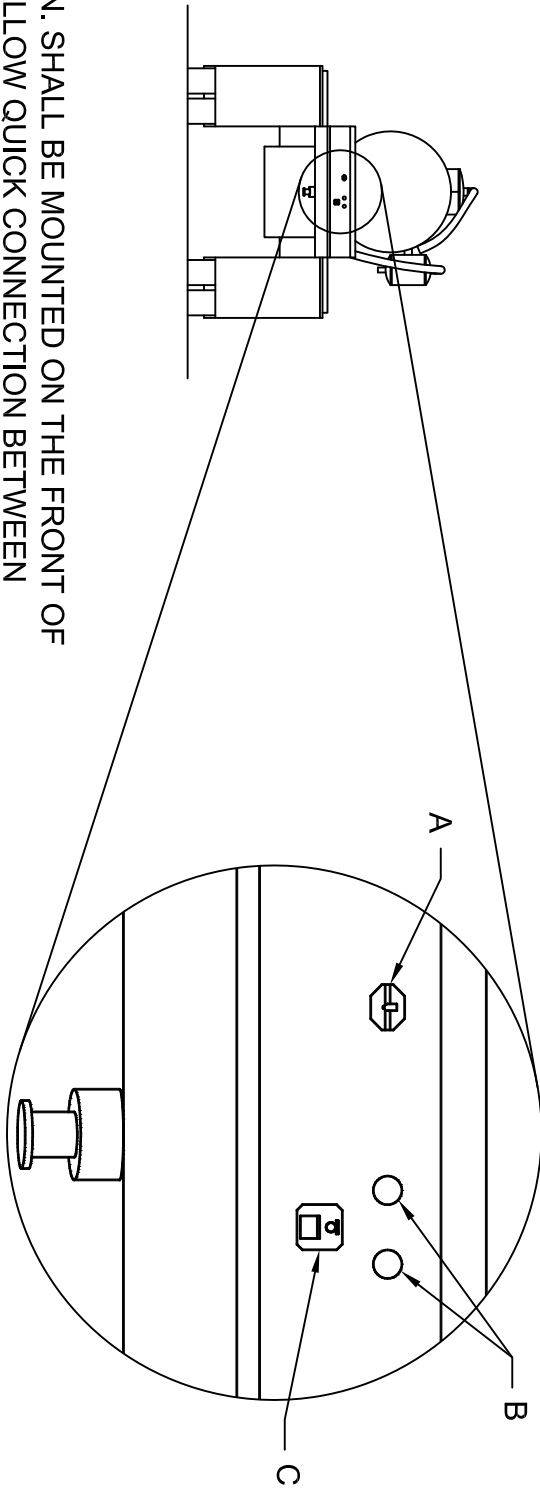
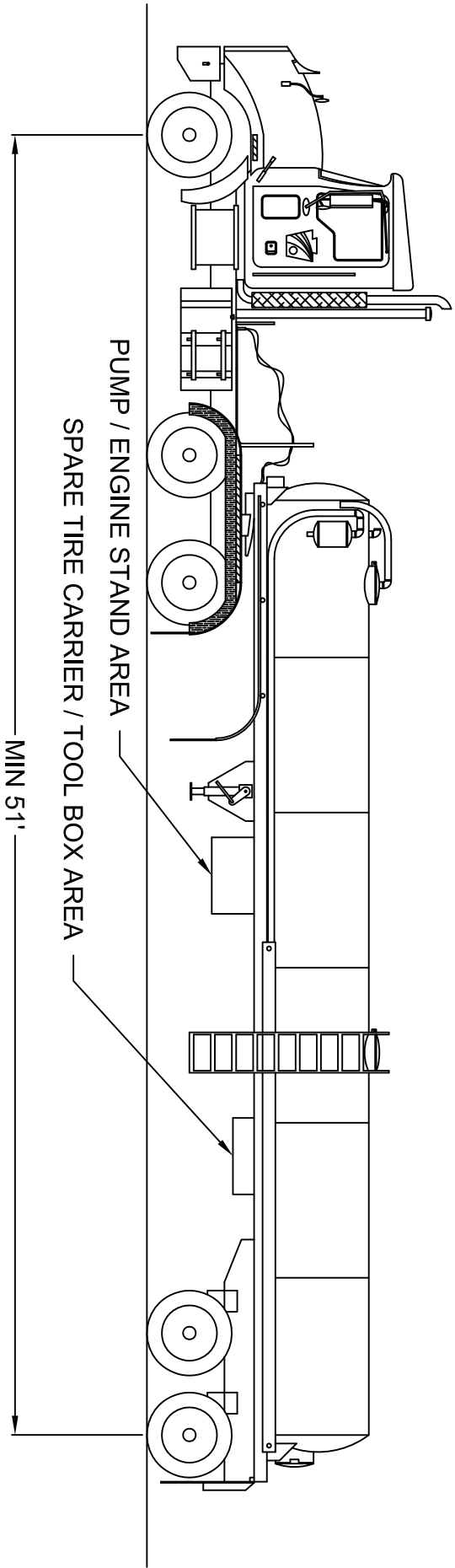

- NOTES:**
- A. 2 PIN CONNECTION. SHALL BE MOUNTED ON THE FRONT OF THE TRAILER TO ALLOW QUICK CONNECTION BETWEEN TRACTOR AND TRAILER.
 - B. STANDARD AIR LINE CONNECTION. SHALL BE MOUNTED ON THE FRONT OF THE TRAILER TO ALLOW QUICK CONNECTION BETWEEN TRACTOR AND TRAILER.
 - C. 7 PIN CONNECTION. SHALL BE MOUNTED ON THE FRONT OF THE TRAILER TO ALLOW QUICK CONNECTION BETWEEN TRACTOR AND TRAILER. REFERENCE EQN-81A.

PA DEPARTMENT OF TRANSPORTATION

REVISIONS			DRAWN BY		
NO.	DATE	BY	JJB	SCALE	
1				N/A	
2					
3					

BRINE / WATER
TRANSPORT TRAILER

DATE 05-20-16
SHEET 1 OF 1

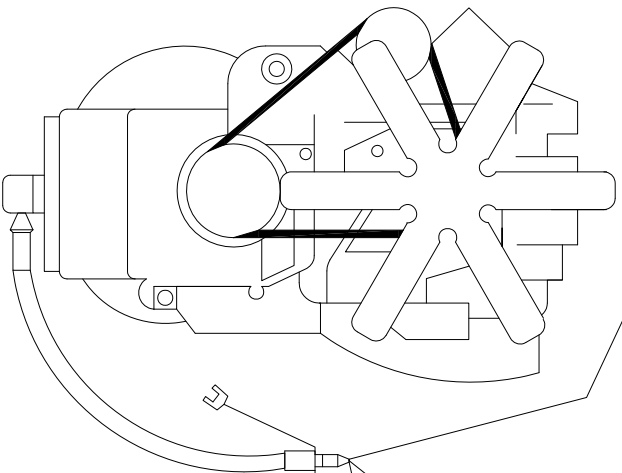
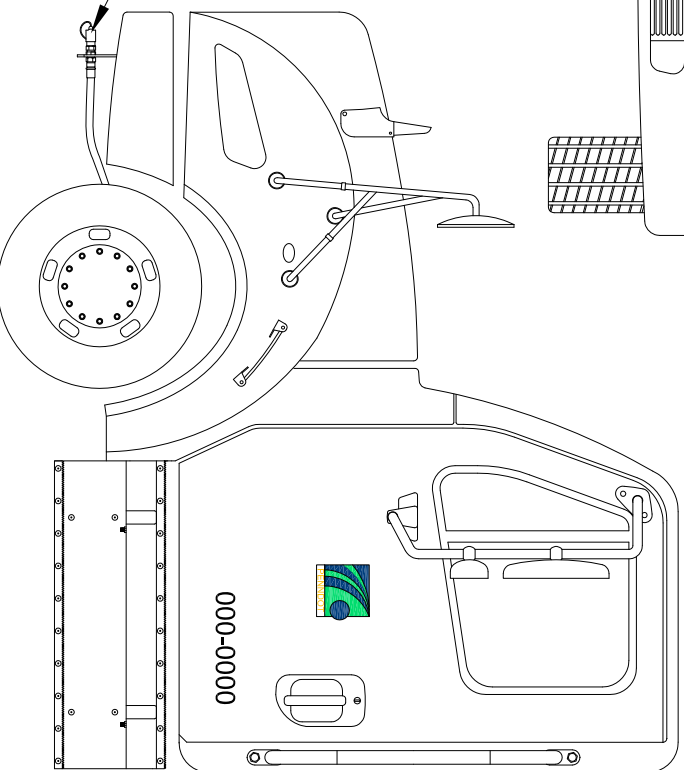
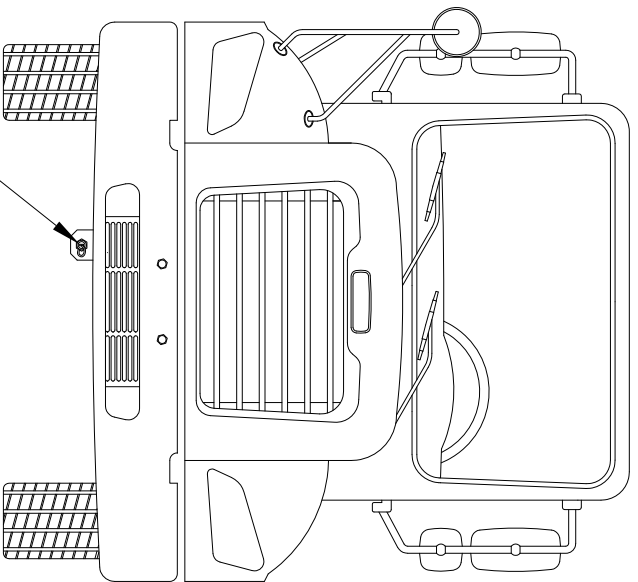
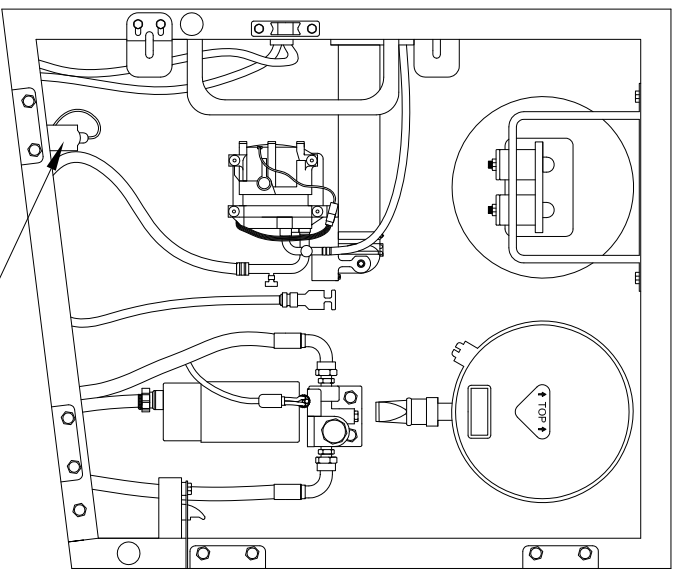

DISCONNECT
COUPLING
FLOCS
ENGINE KIT

PA DEPARTMENT OF TRANSPORTATION

REVISIONS

NO.	DATE	BY	SCALE
1	07-01-03	BLD	N/A
2	10-20-06	CJW	N/A
3	06-19-13	JFM	N/A

**FAST LUBE OIL CHANGE SYSTEM
OVERVIEW AND PARTS LIST**

NO.	DATE	BY	SCALE
1	07-01-03	BLD	N/A
2	10-20-06	CJW	N/A
3	06-19-13	JFM	N/A

000-0000



1. CONTACT AEROQUIP WITH YOUR DRAIN PAN PLUG SIZE
2. AEROQUIP DEALER TELEPHONE NUMBERS:

ADVANCED FLUID CONNECTORS..... 717-757-1068
 AIR BRAKE & POWER EQUIPMENT CO.. 717-622-6188
 AMERICAN BEARING & POWER..... 717-569-3291
 GOODALL RUBBER COMPANY 610-534-2100
 POWER DRIVES INC..... 814-833-8181
 R L MILLER INC..... 412-833-6800
 R L MILLER INC..... 814-456-8900
 SRG/BEVCO..... 610-358-3100
 VOTO MANUFACTURERS SALES CO.... 814-226-7101

FLOCS SHALL INCLUDE, BUT NOT LIMITED TO:

- A. DUST CAP 5657-12
- B. HOSE TO SUIT LENGTH
- C. HOSE FITTING TO SUIT
- D. ADAPTER TO SUIT
- E. HOSE CLAMP #900729-6
- F. BRACKET TO SUIT
- G. COUPLING 5602-12-12S

PA DEPARTMENT OF TRANSPORTATION

REVISIONS			FAST LUBE OIL CHANGE SYSTEM OVERVIEW AND PARTS LIST		
NO	DATE	BY	SCALE	CHK'D BY	
1	07-01-03	BLD	DLW	N/A	EQN-351A
2	10-20-06	CJW			
3	06-19-13	JFM			